



**In-Process
Precision Checking**



**In-House
Heat Treatment**



**German 6-Axis CNC
Spline Grinding**

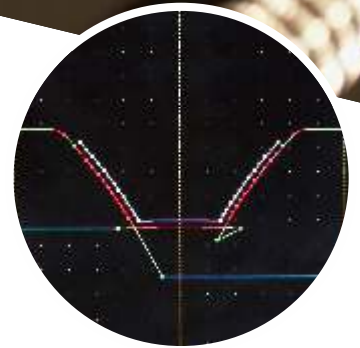

**Proven Broach
Design Expertise**



KHEMKA BROACH & SPLINE GAUGE

Complete Spline Tooling Under One Roof

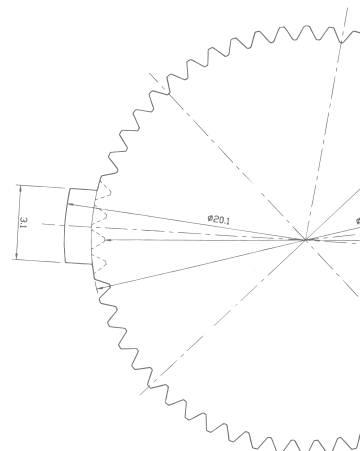

Broaching Tools



OUR CAPABILITIES -

- Manufacturing broaches up to 2100mm long and Ø150mm.
- Re-sharpening of broaches up to 3500mm long and Ø400mm using CNC Machines and CBN Wheels.
- Solution for Dry Broaching and Hi-Speed Broaching.

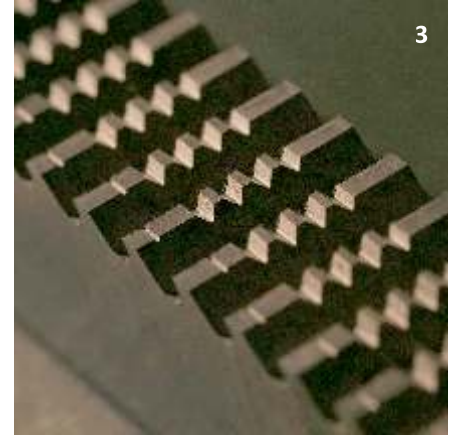
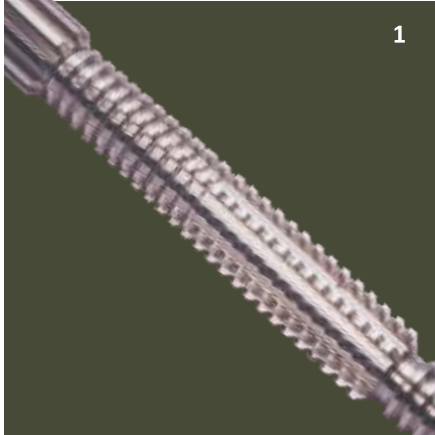

1. CALIBRATING BROACHING TOOLS - These Broaches are used for removing burrs generated during subsequent machining operation and for removing heat treatment salts or minor distortions after hardening. They are also used for finishing sizes when regular Broach is gone under-size but still the sharpening life is available.

2. INVOLUTE SPLINE / SERRATION BROACHING TOOLS - Involute Spline broaches are made according to ANSI B92.1, B92.2M, JIS, DIN 5482, DIN 5480, TSZ 2102K, HES, SES and other related standards. Serration broach can be made for all standards like DIN 5481, SMMT 111, HES, ZGN, DBN and other related standards.

3. SURFACE BROACHING TOOLS - Surface broaches are available as either individual broaches or as inserts for broaching flat surface, irregular surfaces, external forms, concave or convex surface, serrations, cam shaped, corner squaring and dove tails.

4. KEYWAY BROACHING TOOLS, BUSHES & SHIMS - Push or pull type keyways, with deburring feature are made for single or multipass operation. We also manufacture guide bushes to guide keyway broaches during broaching operation.

5. POLYGON SHAPED BROACHING TOOLS - Polygon broaches include square, hexagon, octagon or any polygon shaped broach. These can be designed for sharp or rounded corners. We can also design & manufacture 'Round with Two Flats' broaches and other special profile broaches.

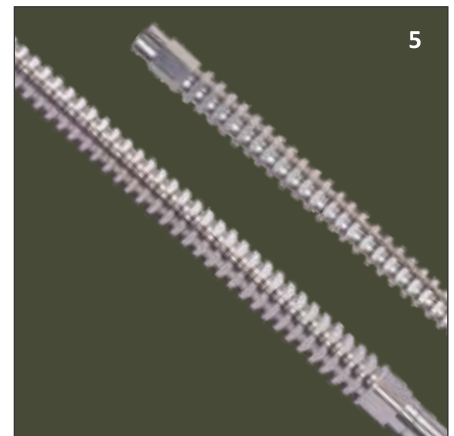
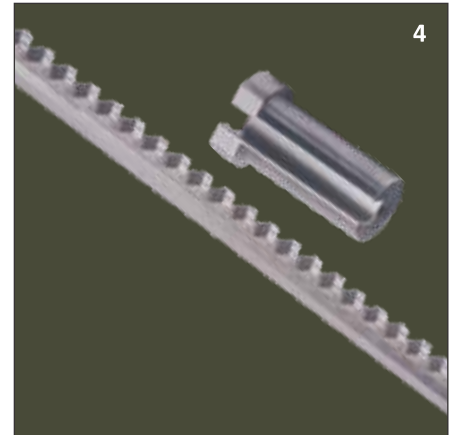

Advanced **Broaching Tools**

1. HELICAL BROACHING TOOLS - Spur type Broaches can be designed with Helical Gullets for very thin components. On the other hand Helical Gullet with Helical Splines result in Helix on the component. Broaches with helical gullets or helical splines or Both can be designed and manufactured by us depending on customer requirements.

2. FULL FORM BROACHING TOOLS - Full Form Shells are used for broaching high precision components like Ring Gears. Full Form Shells remove the material along the profile & hence result in high accuracy in components & also eliminate the possibility of pre-mature wear. We can manufacture and re-sharpen Full Form Shells for both Spur and Helical Broaches.

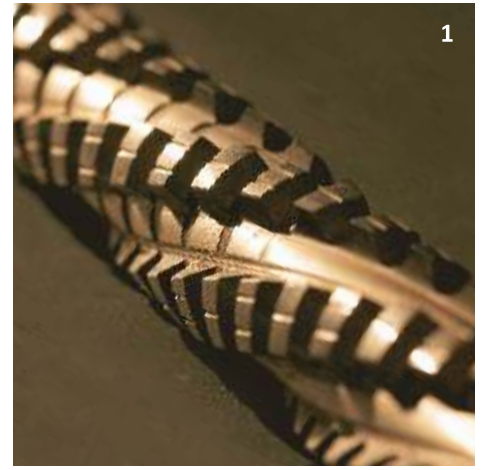

Spline Gauges

PLUG GAUGES - Involute, Serration, Straight Sided, Parallel or Tapered.

Manufacturing Range
Diameter : 4mm - 350mm
Module : 0.3 - 12.0

RING GAUGES - Involute, Serration, Straight Sided, Cross Cut, Parallel or Tapered. Master Plug Gauge for wear control. We also manufacture Internal Ring Gauges having a diameter less than 20mm.

Manufacturing Range
Diameter : 6mm - 120mm
Module : 0.3 - 4.0

MANDRELS - Spline Turning Mandrel, Runout Checking Mandrel, Master Taper Mandrel, Hysteresis Checking Mandrel, Parallel and Taper in all tooth forms.

Manufacturing Range
Diameter : 4mm - 350mm
Module : 0.3 - 12.0



Broaching Machine

This machine has been developed after many years of experience in the field of broaching. We believe we have incorporated the most worthwhile features and also developed new ideas to enable us to produce a first class machine at a very attractive price. The machine is based on latest DIN standards and pull end as per DIN 1417. The machine has been recently upgraded according to **European Safety Certification (CE)**. The PLC Control together with the automation sensors enables Robot operation. Our Range of manufacture (with or without retriever)

- 3 Tons - 10 Tons Pulling Force
- 600mm - 1000mm Movement Stroke

Broach Holders

Full range of SJ, SK & SR type of holders as per DIN-1418 are manufactured by us. These are suitable for Shank J, K or R DIN 1417 & standard broaching machines. They serve to hold broaches with round & flat shanks in the pulling mechanism. These can be used on all horizontal & vertical broaching machines according to size.

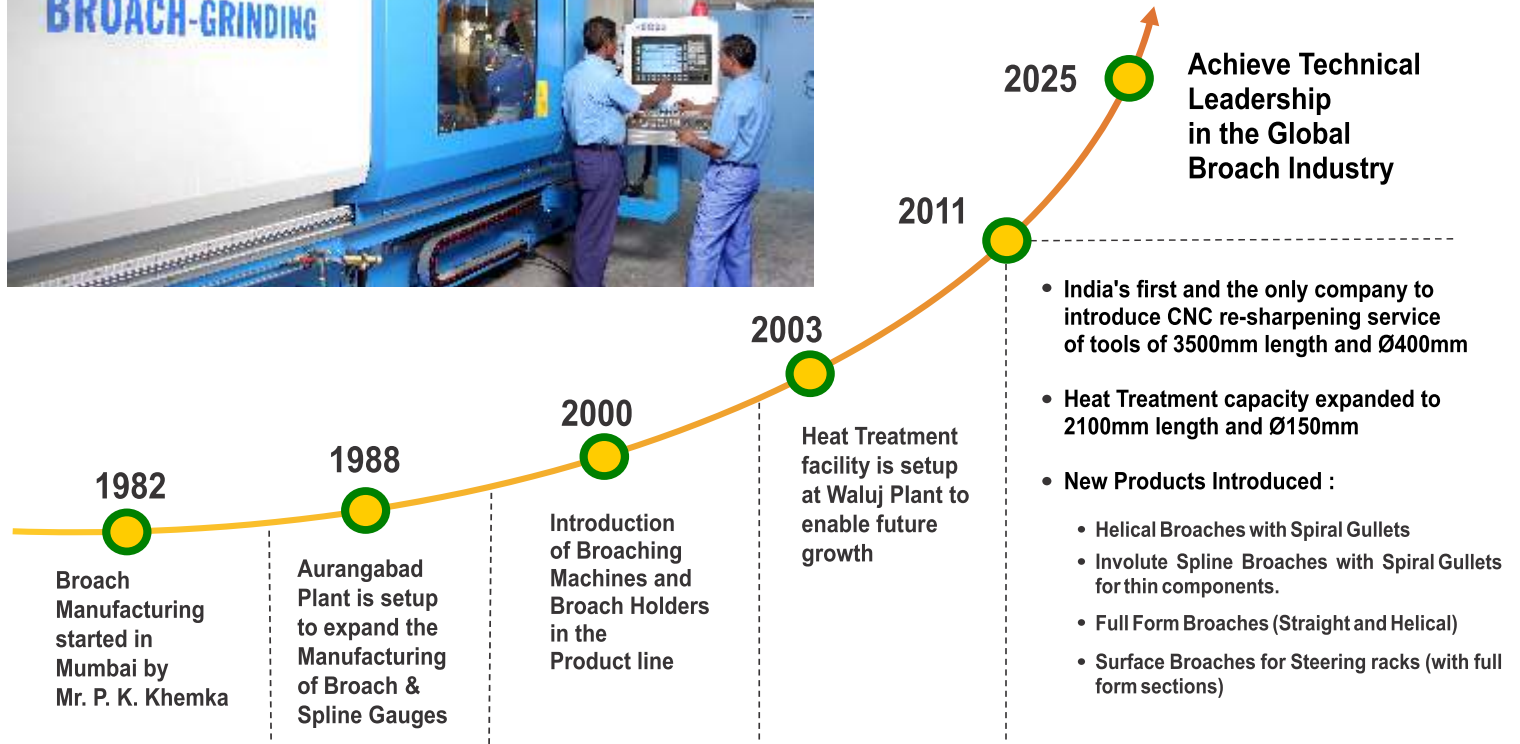

KHEMKA BROACH & SPLINE GAUGE

H-5/39, MIDC, Chikalthana, Aurangabad - 431 006, MH. INDIA
Tel. : +91 240 2484712 / 2485517 e-Fax : +1 248 5256972



BROACH TECHNOLOGY (INDIA) PVT. LTD.

K-219/220, MIDC, Waluj, Aurangabad - 431 136, MH. INDIA
Tel. : +91 240 2484712 / 2485517 e-Fax : +1 248 5256972

Email : sales@khemkabroach.com Website : www.khemkabroach.com